

# Commer

C50 ENGINE



## INDICE - INDEX

CARATTERISTICHE - <i>FEATURES</i>	PAG. 2
RICAMBI MOTORE - <i>ENGINE SPARE PARTS</i>	PAG. 3 -16
RICAMBI CARBURATORE - <i>CARBURETTOR SPARE PARTS</i>	PAG. 17 - 20
OPTIONALS	PAG. 21 - 24
ACCESSORI - <i>ACCESSORIES</i>	PAG. 25 - 26
ATTREZZI - <i>TOOLS</i>	PAG. 27 - 28
INFORMAZIONI GENERALI E PREZZO MOTORE - <i>GENERAL INFO AND ENGINE PRICE</i>	PAG. 29

\*\*\* LA NUMERAZIONE DEI COMPONENTI (Pos.) E' PROGRESSIVA

\*\*\* THE NUMBERING OF THE COMPONENTS (Pos.) IS PROGRESSIVE



### NOTE - NOTES

A series of horizontal dotted lines spanning the width of the page, intended for handwritten notes or additional information.



Motore: monocilindrico 2 tempi con raffreddamento forzato ad aria, cilindro in alluminio-NIKASIL, aspirazione tipo PISTON PORT, monomarcia con frizione centrifuga a molle e avviamento a strappo.

**CILINDRATA NOMINALE: 50 c.c.**

**ALESAGGIO x CORSA: 40x38mm**

**POTENZA MAX: 2CV A 6500g/min**

**ACCENSIONE: ELETTRONICA**

**CARBURATORE: A VASCHETTA DELL'ORTO SHA 14-12L**

**MISCELA OLIO/BENZINA: AL 4% (25:1) CON OLIO 2T NON RICINATO**

**PIGNONE DI TRASMISSIONE: Z10 PASSO 219 (7,76mm)**



Engine: 2 stroke single cylinder cooled by forced air, aluminum-NIKASIL cylinder, PISTON PORT inlet system, one gear with centrifugal springs clutch and pull start.

**NOMINAL DISPLACEMENT: 50 c.c.**

**BORE x STROKE: 40x38mm**

**MAX POWER: 2HP AT 6500g/min**

**IGNITION: ELECTRONIC**

**CARBURETTOR: BOWL TYPE DELL'ORTO SHA 14-12L**

**MIXTURE OIL/GASOLINE: 4% (25:1) WITH 2 STROKE OIL NOT CASTOR**

**TRANSMISSION PINION: Z10 - 219 (7,76mm) PITCH**

# C 50 - (disegno 1) - (drawing 1)

1 C 50

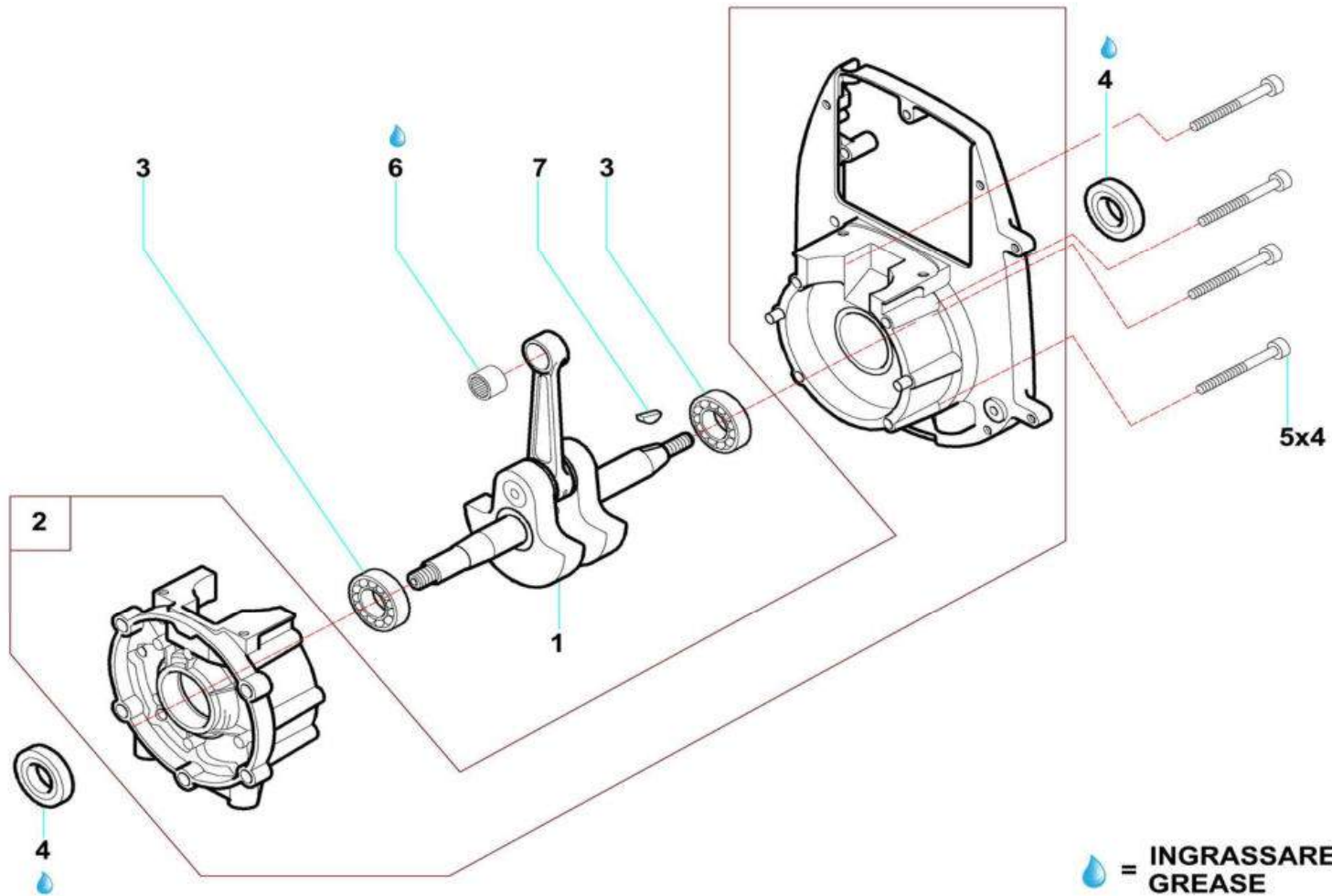

 = INGRASSARE  
GREASE

**Comer**

## C 50 - (disegno 1) - (drawing 1)

---

<b>Pos.</b>	<b>Cod.</b>	<b>Descrizione</b>	<b>Description</b>	<b>Qt.</b>
1	C050-040	Albero motore completo	Complete crankshaft	1
2	C050-044	Basamento completo	Complete crankase	1
3	NORM-042-01	Cuscinetto 6202 C3	Bearing 6202 C3	2
3A**	NORM-042-08	Cuscinetto 6202 C4	Bearing 6202 C4	
4	S060-084	Paraolio COMER D.15xD.30x7 in VITON	COMER VITON oil seal D.15xD.30x7	2
4A**	C050-084	Paraolio D.15xD.30x5,5 anello metallico	Oil seal D.15xD.30x5,5 with metal ring	
5	NORM-080-02	Vite TCEI M5x40 zincata bianca	Screw TCEI M5x40 white galvanized	4
6	C050-048	Astuccio a rulli D.10xD.14x10	Roller cage D.10xD.14x10	1
7	C050-041	Chiavetta volano 2x5	Flywheel key 2x5	1

\*\* OPTIONAL - Non fornito con il motore/Not supplied with the engine

# C 50 - (disegno 2) - (drawing 2)

2 C 50

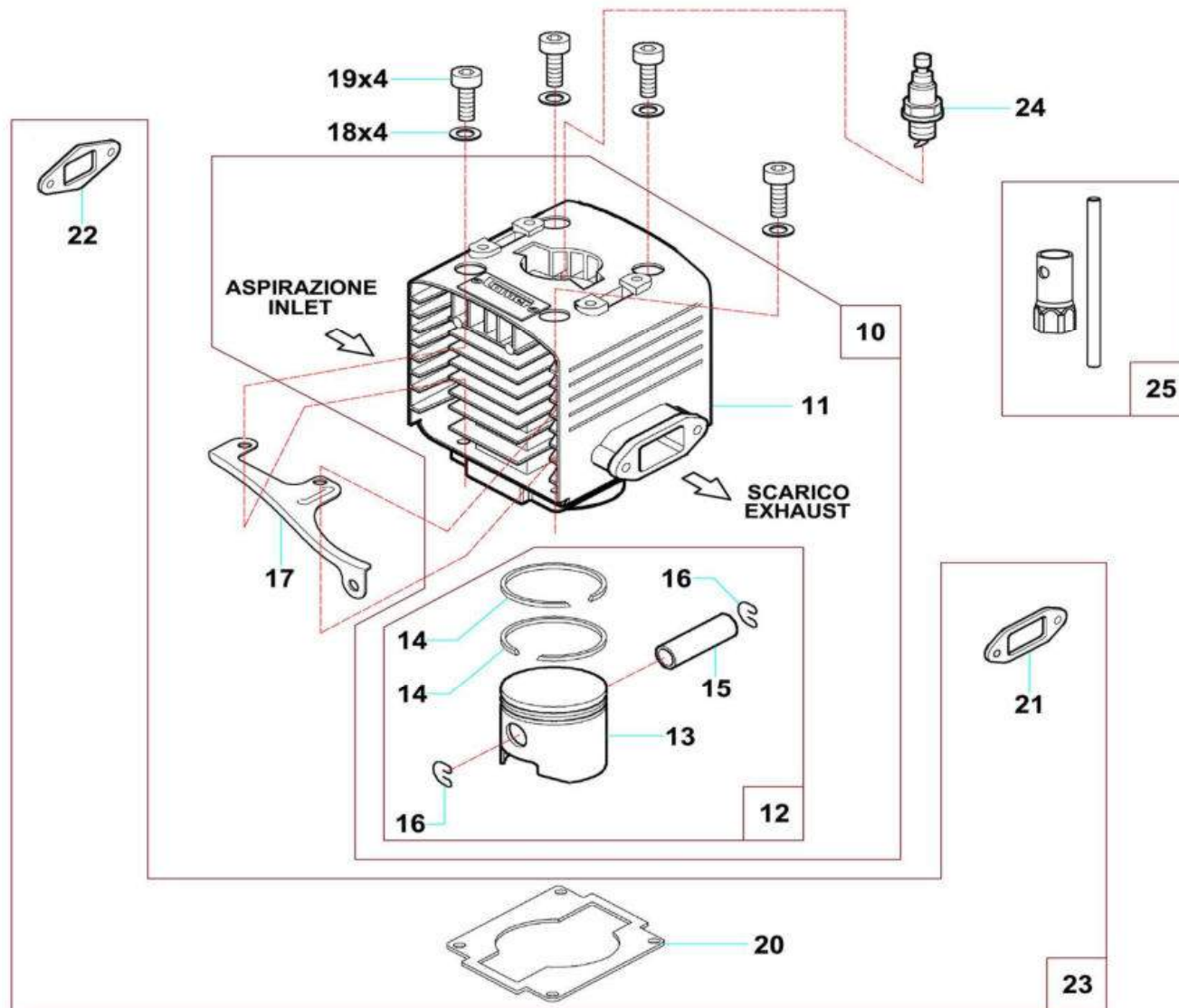

## C 50 - (disegno 2) - (drawing 2)

Pos.	Cod.	Descrizione	Description	Qt.
10	C050-058-05*	Cilindro selezione A completo di pistone	Complete cylinder A selection with piston	1
	C050-058-06*	Cilindro selezione B completo di pistone	Complete cylinder B selection with piston	1
11	C050-058	Cilindro nudo selezione A	Cylinder only A selection	1
	C050-058-01	Cilindro nudo selezione B	Cylinder only B selection	1
12	C050-052	Pistone completo selezione A	Complete piston A selection	1
	C050-052-03	Pistone completo selezione B	Complete piston B selection	1
13	C050-055	Pistone nudo selezione A	Piston only A selection	1
	C050-055-01	Pistone nudo selezione B	Piston only B selection	1
14	70001119	Segmento di compressione D.40	Compression ring D.40	2
15	C050-053	Spinotto pistone D.10xD.6x33	Piston pin D.10xD.6x33	1
16	70001116	Anello ferma spinotto	Piston pin clip	2
17	C051-037-01	Supporto copertura marmitta	Exhaust cover support	1
18	NORM-076-02	Rondella elastica ondulata D.5,5xD.10x0,5	Wave washer D.5xD.10x0,5	4
19	NORM-080-04	Vite TCEI M5x20 brunita	Screw TCEI M5x20 burnished	4
20	C050-057-04	Guarnizione cilindro sp. 0,40	Cylinder gasket 0,40 thickness	1
20A**	C050-057-01	Guarnizione cilindro sp. 0,05	Cylinder gasket 0,05 thickness	
20B**	C050-057-02	Guarnizione cilindro sp. 0,10	Cylinder gasket 0,10 thickness	
20C**	C050-057-03	Guarnizione cilindro sp. 0,20	Cylinder gasket 0,20 thickness	
20D**	C050-057	Guarnizione cilindro sp. 0,30	Cylinder gasket 0,30 thickness	
20E**	C050-057-05	Guarnizione cilindro sp. 0,50	Cylinder gasket 0,50 thickness	
21	C050-035	Guarnizione di scarico	Exhaust gasket	1
22	C050-069	Guarnizione di aspirazione	Inlet gasket	1
23	C050-207	Kit guarnizioni motore	Engine gaskets kit	1
24	C050-068-01	Candela CHAMPION RCJTY	Spark plug CHAMPION RCJTY	1
24A**	S060-068	Candela BOSCH WS5F	Spark plug BOSCH WS5F	
25	KACC-143	Chiave candela 19 con perno	Spark plug key 19 with pin	1

\* Attenzione! I motori sono forniti dalla fabbrica con il cilindro e relativo pistone indifferentemente di selezione A oppure B

\* Attention! The engines are supplied by the factory with cylinder and proper piston indifferently A or B selection

Si raccomanda di montare il cilindro e il pistone con la stessa selezione

We recommend to assembly the cylinder and the piston having same selection

\*\* OPTIONAL - Non fornito con il motore/Not supplied with the engine

# C 50 - (disegno 3) - (drawing 3)

3 C 50

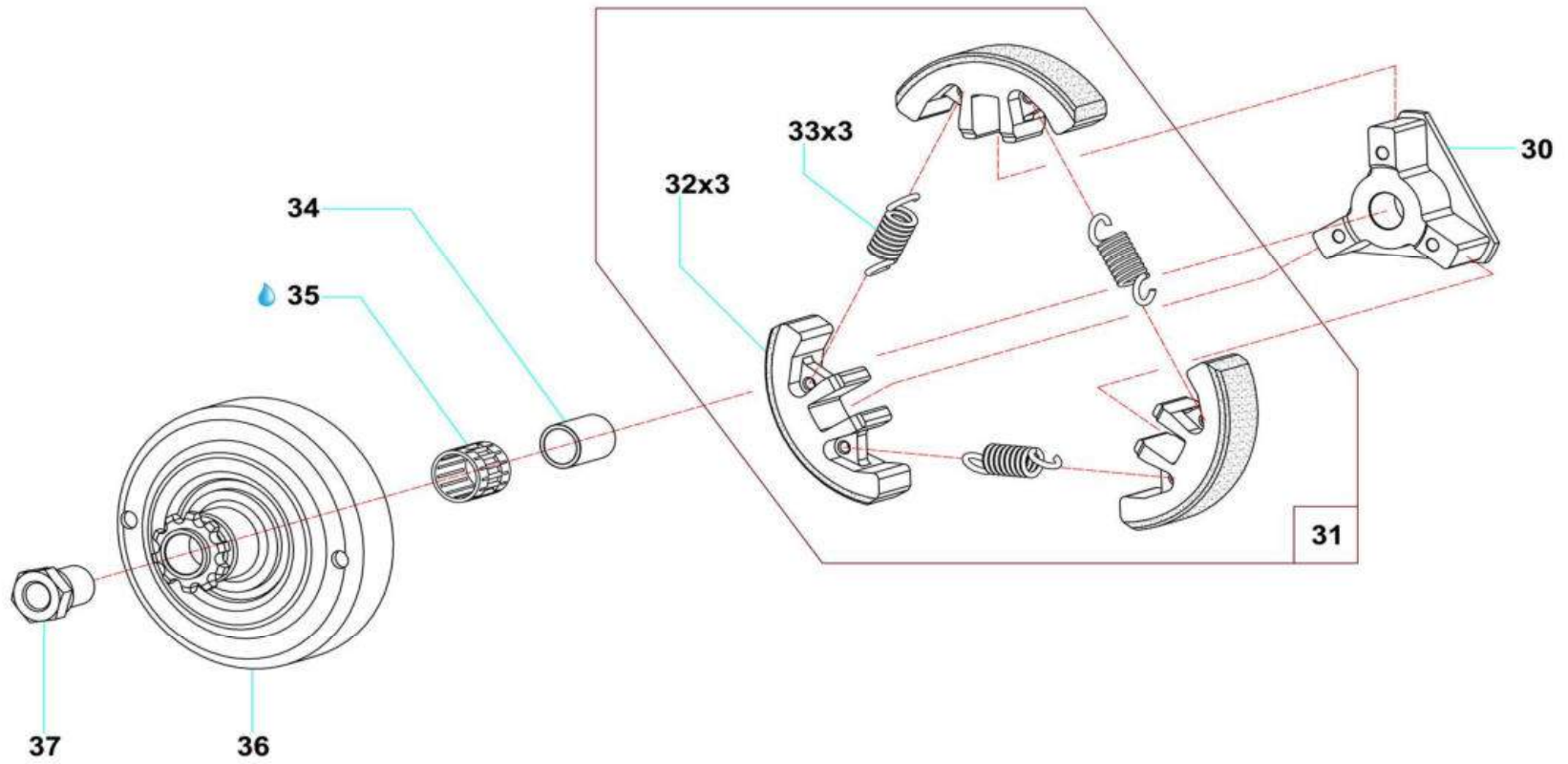

 = INGRASSARE  
GREASE



## **C 50 - (disegno 3) - (drawing 3)**

---

<b>Pos.</b>	<b>Cod.</b>	<b>Descrizione</b>	<b>Description</b>	<b>Qt.</b>
30	S080-086	Trascinatore frizione	Clutch driver	1
31	S080-089	Frizione centrifuga a molle	Centrifugal springs clitch	1
32	S080-087	Pattino frizione a secco	Dry clutch shoe	3
33	S080-085	Molla frizione	Clutch spring	3
34	S060-091-01	Boccola per gabbia a rulli per cono piccolo	Bush for small cone roller cage	1
35	NORM-092	Gabbia arulli D.15xD.18x17	Roller cage D.15xD.18x17	1
36	S060-099-02	Campana frizione speciale Z10	Special Z10 clutch drum	1
**		<b>VEDERE ANCHE OPTIONAL 1 PAG. 21/22</b>	<b>SEE ALSO OPTIONAL 1 PAGE 21/22</b>	
37	C050-094	Dado speciale ch.17	Special nut hexagon 17	1

\*\* OPTIONAL - Non fornito con il motore/Not supplied with the engine

# C 50 - (disegno 4) - (drawing 4)

**4**    **C 50**

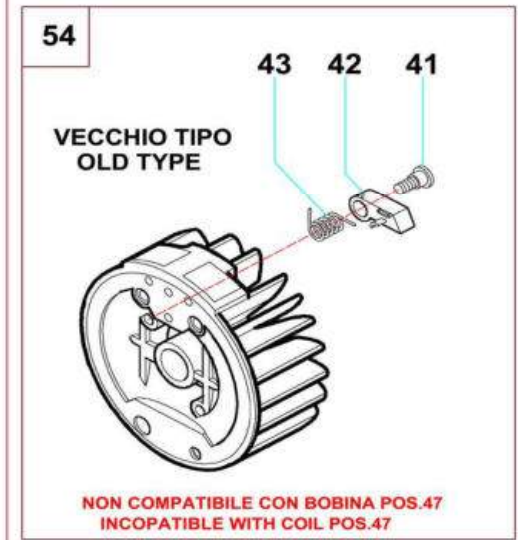
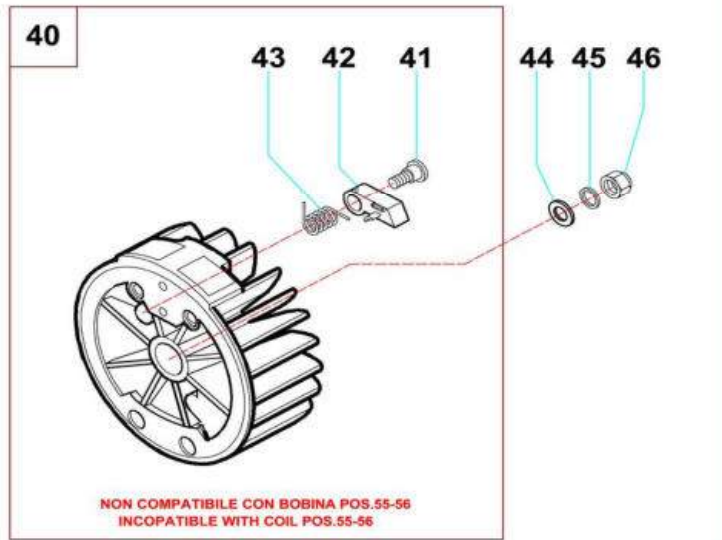
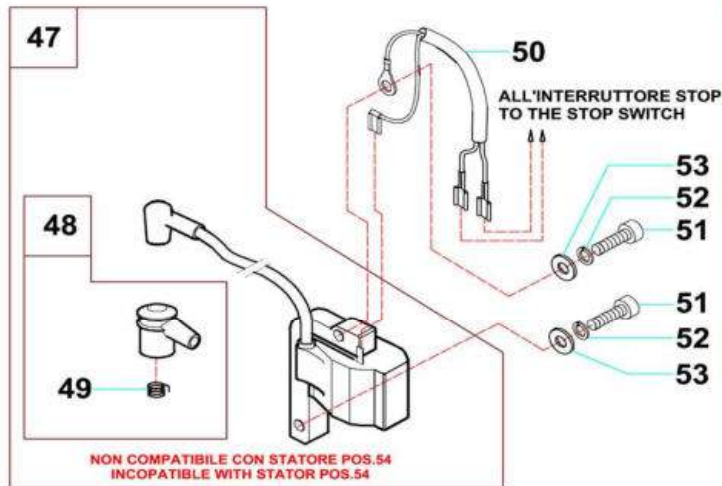

**ATTENZIONE !!**  
LE BOBINE A POS.55-56 SONO COMPATIBILI SOLO CON LO STATORE A POS.54

**ATTENTION !!**  
THE COILS POS.55-56 ARE COMPATIBLE ONLY WITH THE STATOR POS.54



## C 50 - (disegno 4) - (drawing 4)

<b>Pos.</b>	<b>Cod.</b>	<b>Descrizione</b>	<b>Description</b>	<b>Qt.</b>
40	C050-453-02	Volano FJ completo	Complete FJ flywheel	1
41	C050-027	Perno cricchetto	Ratchet pin	2
42	C050-025	Arpioncino	Hook	2
43	C050-026	Molla arpioncino	Hook spring	2
44	C050-020	Rondella piana D.8,3xD.17x1,6 brunita	Flat washer D.8,3xD.17x1,6 burnished	1
45	NORM-168	Rondella elastica Grower D.8,3xD.14,5x2 z.b.	Grower washer D.8,3xD.14,5x2 white galvanized	1
46	C050-019	Dado M8x6,5 zincato bianco	Nut M8x6,5 white galvanized	1
47	C050-425-02	Bobina completa FJ	Complete FJ coil	1
48	C050-033	Cappuccio candela con molla	Spark plug cap with spring	1
**		VEDERE ANCHE OPTIONAL 1 PAG. 21/22	SEE ALSO OPTIONAL 1 PAGE 21/22	
49	70001095	Molla per cappuccio candela	Spark plug cap spring	1
50	C051-425-01	Cablaggio interruttore di STOP	Stop switch wiring	1
51	NORM-003-09	Vite TB TX20 M4x20	Screw TB TX20 M4x20	2
52	NORM-168-02	Rondella elastica Grower D.4,3xD.7,5x1 z.b.	Grower washer D.4,3xD.7,5x1 white galvanized	2
53	NORM-166-02	Rondella piana D.4,5xD.8,5x0,9 z.b.	Flat washer D.4,5xD.8,5x0,9 white galvanized	2
54	C050-453	Volano SELETTTRA completo (precedente)	Complete SELETTTRA flywheel (previous)	1
55	C051-425	Bobina compl. SELETTTRA nera (precedente)	Complete SELETTTRA flywheel black (previous)	1
56	C050-425	Bobina compl. SELETTTRA azzurra (preced.)	Complete SELETTTRA flywheel blue (previous)	1

\*\* OPTIONAL - Non fornito con il motore/Not supplied with the engine

# C 50 - (disegno 5) - (drawing 5)

5 C 50

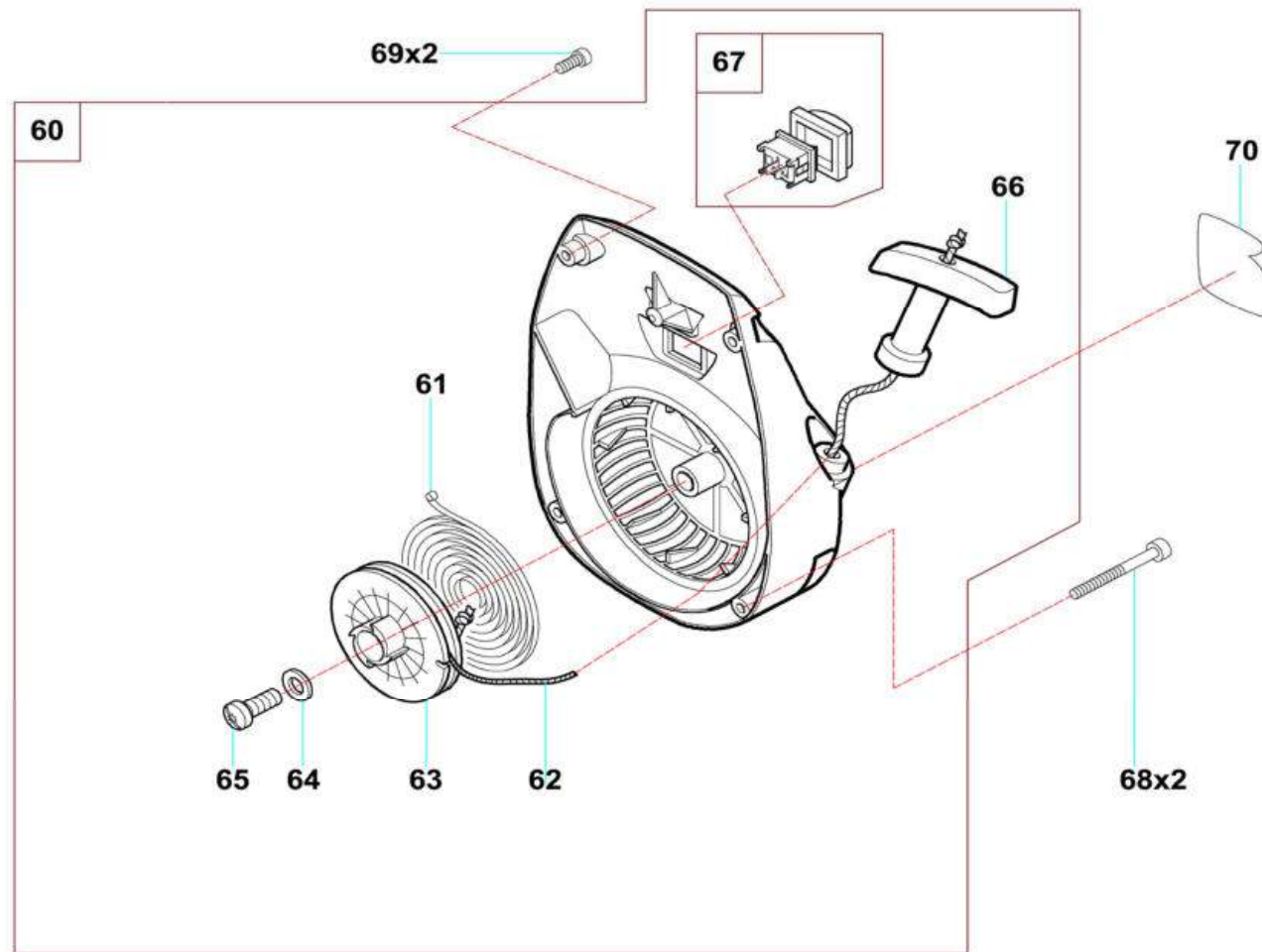

**Comer**

## **C 50 - (disegno 5) - (drawing 5)**

---

<b>Pos.</b>	<b>Cod.</b>	<b>Descrizione</b>	<b>Description</b>	<b>Qt.</b>
60	C051-001	Avviamento completo	Complete starter	1
61	7000-1051	Molla avviamento	Starter spring	1
62	C050-007	Funicella avviamento D.3,5	Starter rope D.3,5	1
63	C050-006	Tamburo funicella	Rope drum	1
64	C050-010	Rondella piana D.5,3xD.15x1,2 zincata bianca	Flat washer D.5,3xD.15x1,2 white galvanized	1
65	C050-011	Vite autofilettante TB TX20 D.5x15	Self tapping screw TB TX20 D.5x15	1
66	C050-008	Impugnatura	Handle	1
67	C050-003	Interruttore di STOP con protezione	STOP switch with cover	1
68	NORM-003-10	Vite TB TX27 M5x40	Screw TB TX27 M5x40	2
69	NORM-003-11	Vite TB TX27 M5x22	Screw TB TX27 M5x22	2
70	C050-005	Adesivo Comer C50	Comer C50 sticker	1

# C 50 - (disegno 6) - (drawing 6)

6 C 50

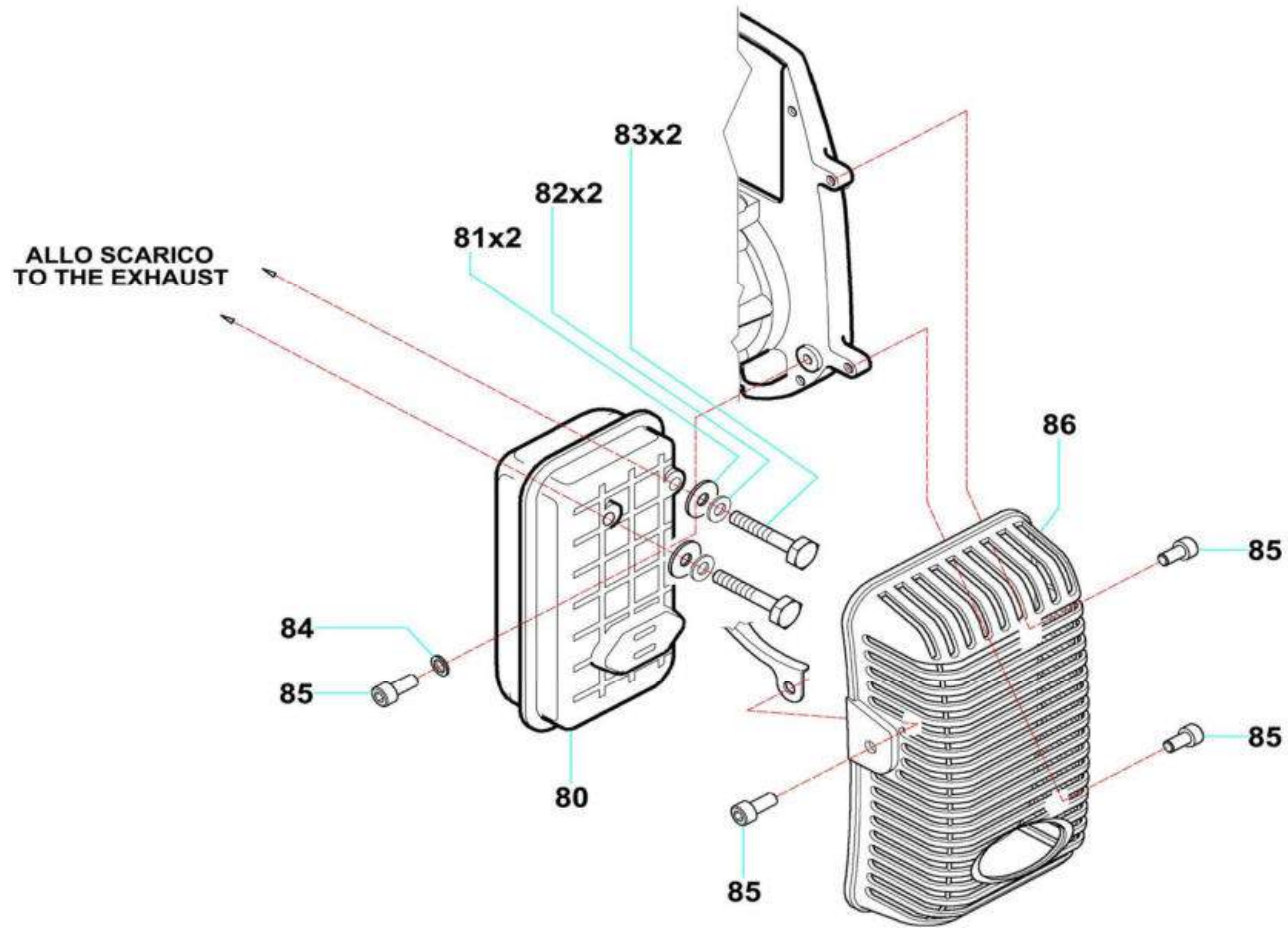

**Comer**

## C 50 - (disegno 6) - (drawing 6)

---

<b>Pos.</b>	<b>Cod.</b>	<b>Descrizione</b>	<b>Description</b>	<b>Qt.</b>
80	C050-034-01	Marmitta a bauletto	Exhaust box	1
**		VEDERE ANCHE OPTIONAL 1 PAG. 21/22	SEE ALSO OPTIONAL 1 PAGE 21/22	
81	C050-010	Rondella piana D.5,3xD.15x1,2 zincata bianca	Flat washer D.5,3xD.15x1,2 white galvanized	2
82	NORM-076-02	Rondella elastica ondulata D.5,5xD.10x0,5	Wave washer D.5xD.10x0,5	4
83	NORM-036-04	Vite TE M5x70 brunita	Screw TE M5x70 burnished	2
84	NORM-144-02	Rondella piana D.5,5xD.12x1,3 zincata bianca	Flat washer D.5,5xD.12x1,3 white galvanized	1
85	NORM-003-12	Vite TB TX20 M5x12	Screw TB TX20 M5x12	4
86	C051-037	Protezione scarico in plastica	Plastic exhaust cover	1

\*\* OPTIONAL - Non fornito con il motore/Not supplied with the engine

# C 50 - (disegno 7) - (drawing 7)

7 C 50

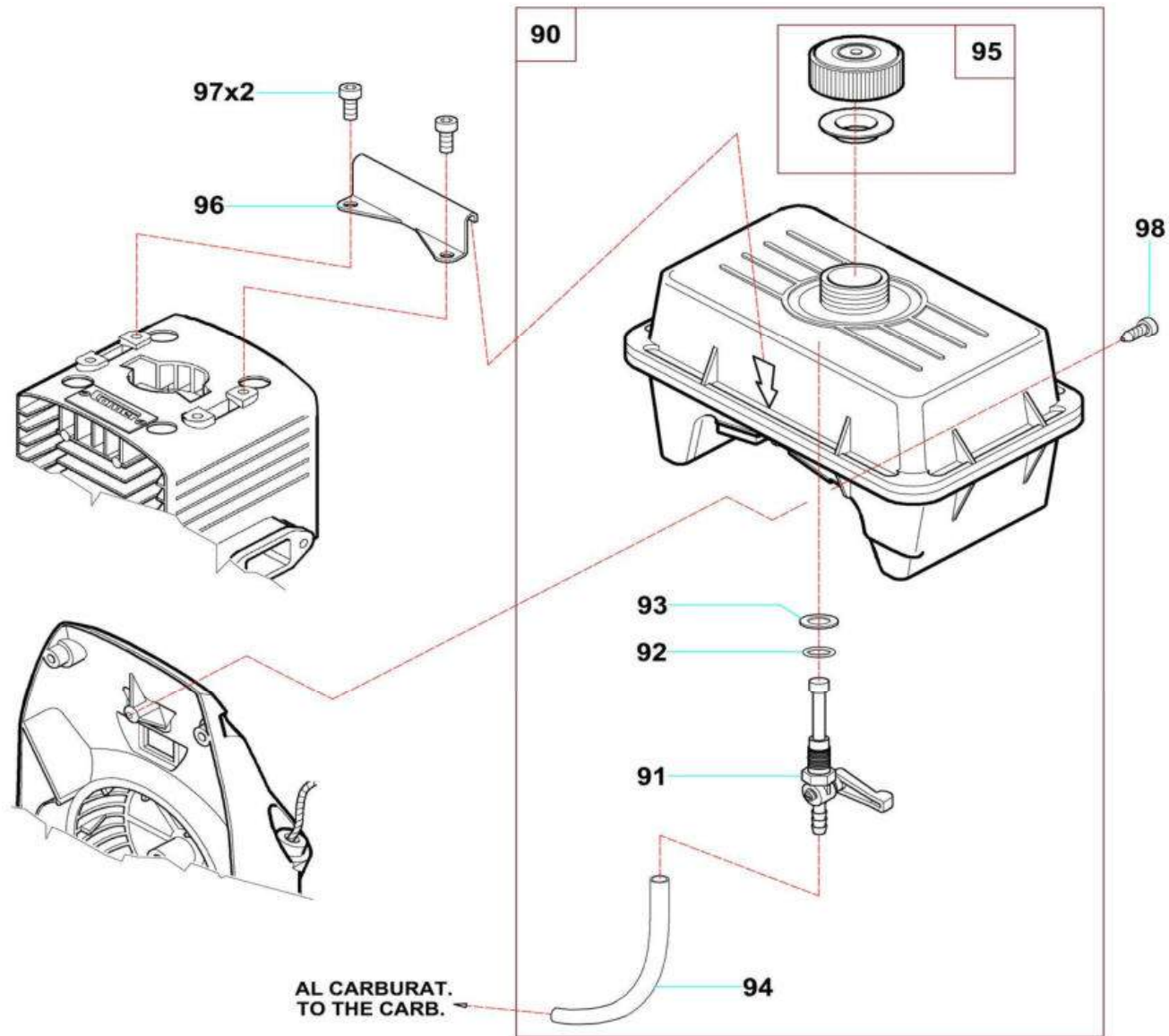



## **C 50 - (disegno 7) - (drawing 7)**

---

<b>Pos.</b>	<b>Cod.</b>	<b>Descrizione</b>	<b>Description</b>	<b>Qt.</b>
90	C050-426	Serbatoio benzina completo	Complete fuel tank	1
91	C050-430	Rubinetto serbatoio	Fuel tank tap	1
92	C050-430-02	O.Ring rubinetto	Tap O.Ring	1
93	C050-430-03	Rondella serbatoio in alluminio D.12xD.16x1	Fuel tank aluminum washer D.12xD.16x1	1
94	C050-430-05	Tubo serbatoio D.4xD.8 L=130	Fuel tank tube D.4xD.8 L=130	1
95	C050-427	Tappo serbatoio con guarnizione	Fuel tank cap with gasket	1
96	C050-428	Staffa fissaggio serbatoio	Fuel tank bracket	1
97	NORM-090	Vite TCEI M5x12 zincata bianca	Screw TCEI M5x12 white galvanized	2
98	C050-011	Vite autofilettante TB TX20 D.5x15	Self tapping screw TB TX20 D.5x15	1

# C 50 - (disegno 8) - (drawing 8)

8 C 50

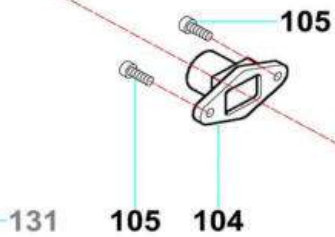
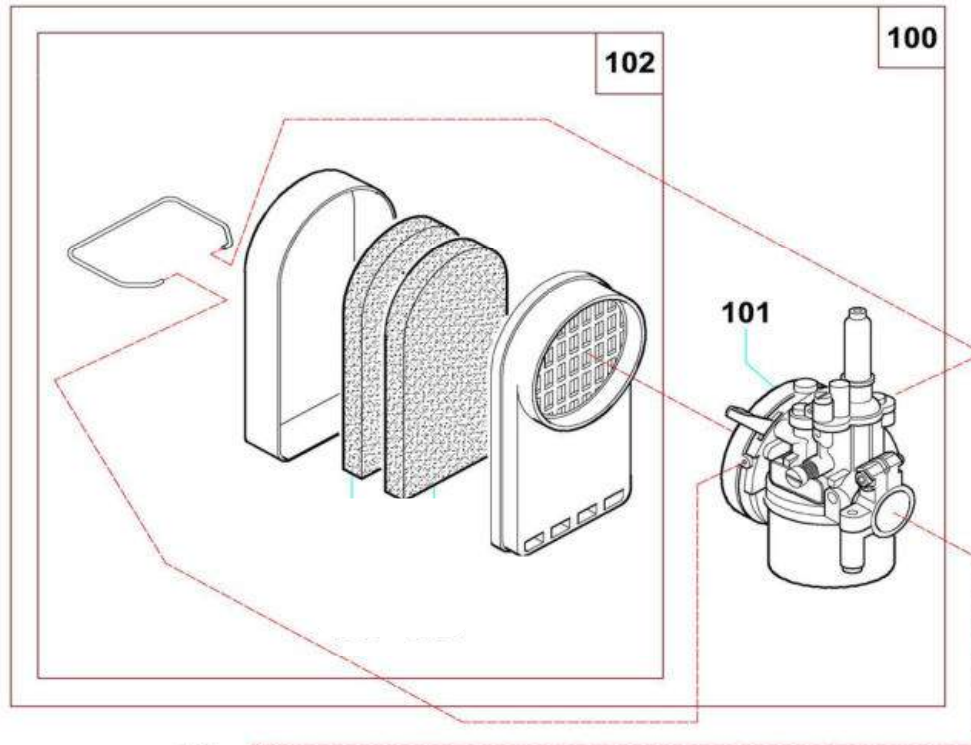

ALLA ASPIRAZIONE  
TO THE INLET

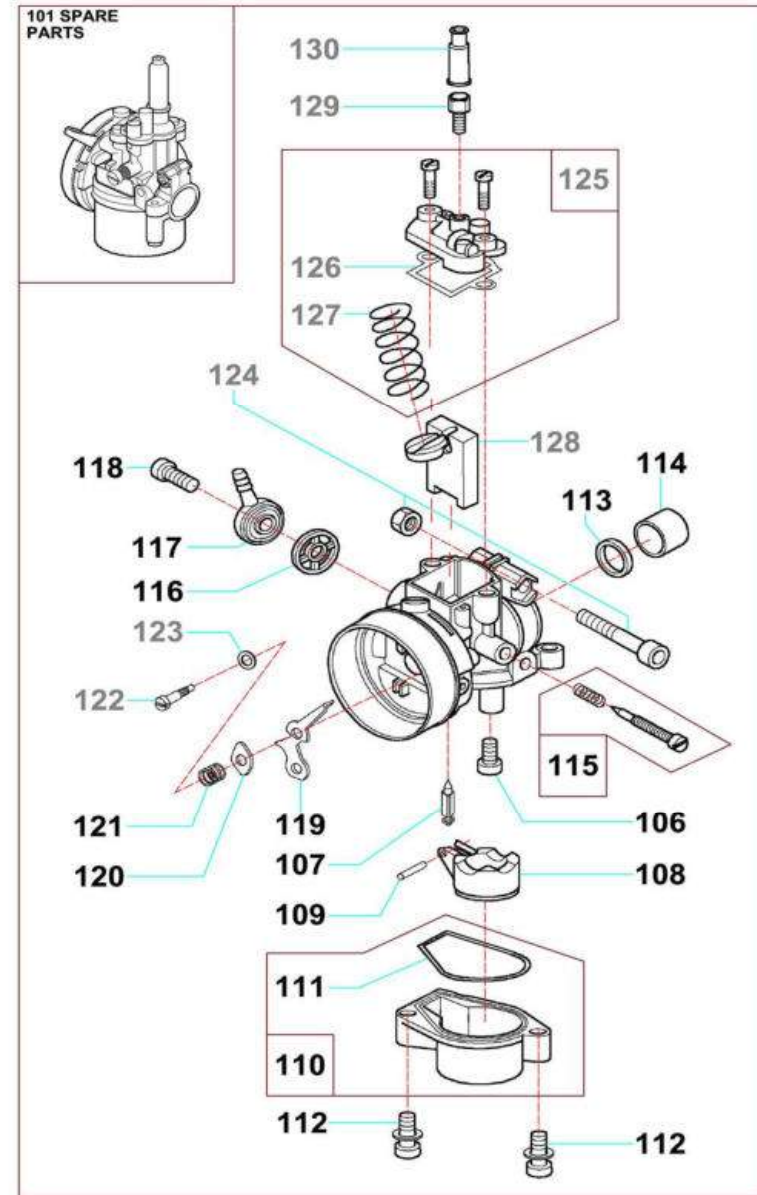

## C 50 - (disegno 8) - (drawing 8)

<b>Pos.</b>	<b>Cod.</b>	<b>Descrizione</b>	<b>Description</b>	<b>Qt.</b>
100	C050-074	Carburat. Dell'Orto SHA 14-12L completo di filtro	Dell'Orto carb. SHA 14-12L compl. with air filter	1
101	C050-074-01	Carburat. Dell'Orto SHA 14-12L	Dell'Orto carb. SHA 14-12L	1
102	C050-079	Cassetta filtro aria completa	Complete air box filter	1
104	C050-070	Collettore di aspirazione	Inlet manifold	1
**		VEDERE ANCHE OPTIONAL 2 PAG. 23/24	SEE ALSO OPTIONAL 2 PAGE 23/24	
105	NORM-039-01	Vite TCEI M5x14 zincata bianca	Screw TCEI M5x14 white galvanized	2
106	C050-436	Getto max 58	Max jet 58	1
106A**	C050-436-01	Getto max 50	Max jet 50	
106B**	C050-436-10	Getto max 51	Max jet 51	
106C**	C050-436-11	Getto max 52	Max jet 52	
106D**	C050-436-12	Getto max 53	Max jet 53	
106E**	C050-436-02	Getto max 54	Max jet 54	
106F**	C050-436-03	Getto max 55	Max jet 55	
106G**	C050-436-04	Getto max 56	Max jet 56	
106H**	C050-436-05	Getto max 57	Max jet 57	
106I**	C050-436-06	Getto max 59	Max jet 59	
106L**	C050-436-07	Getto max 60	Max jet 60	
106M**	C050-436-08	Getto max 61	Max jet 61	
106N**	C050-436-09	Getto max 62	Max jet 62	
107	C050-437	Spillo chiusura benzina	Fuel closing needle	1
108	C050-450	Galleggiante 1	Float 1	1
109	C050-438	Perno galleggiante	Float pin	1
110	C050-452	Vaschetta con guarnizione	Bowl with gasket	1
111	C050-451	Guarnizione vaschetta	Bowl gasket	1
112	C050-440-01	Vite vaschetta con rondella	Bowl screw with washer	2
113	C050-432	Guarnizione riduzione isolante	Insulating reduction gasket	1
114	C050-431	Riduzione isolante	Insulating reduction	1
115	C050-435-01	Kit vite regolazione valvola gas	Throttle gas gas setting screw	1
116	C050-443-01	Filtro benzina	Fuel filter	1
117	C050-443-02	Raccordo tubo benzina	Fuel tube fitting	1
118	C050-443-03	Vite raccordo tubo benzina	Fuel tube fitting screw	1
119	C050-446	Valvola aria 50	Air valve 50	1
120	C050-446-01	Rondella sagomata	Shaped washer	1
121	C050-446-02	Molla perno valvola aria	Air valve pin spring	1

\*\* OPTIONAL - Non fornito con il motore/Not supplied with the engine

continua a pag.20/continues on pag. 20

# C 50 - (disegno 8) - (drawing 8)

8 C 50

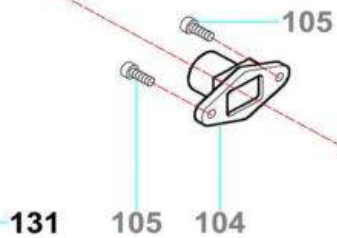
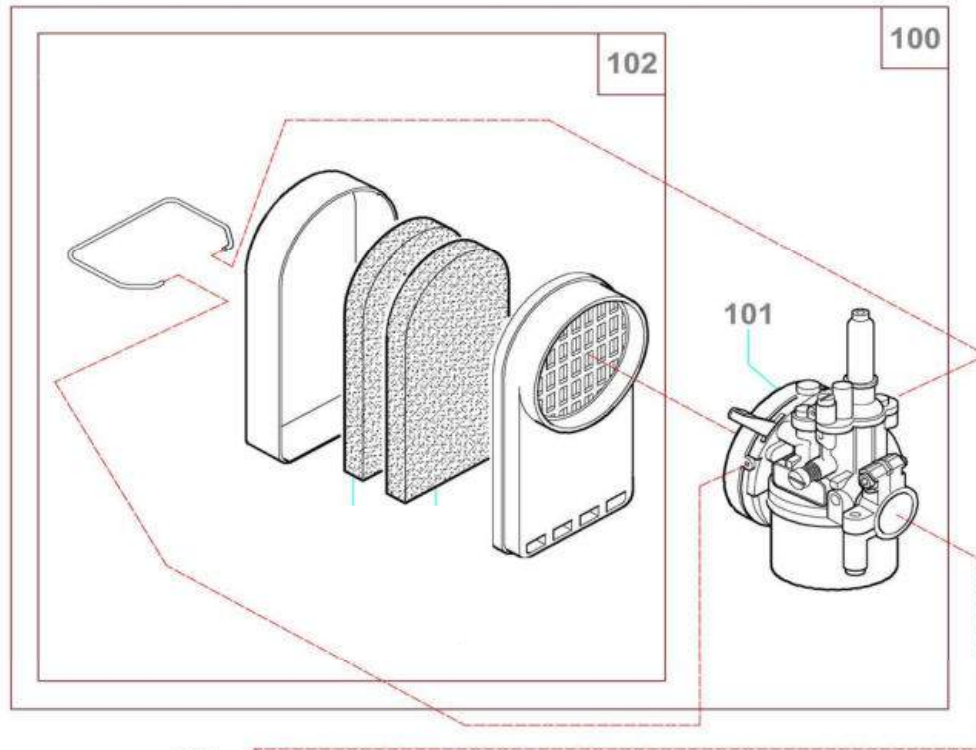

ALLA ASPIRAZIONE  
TO THE INLET

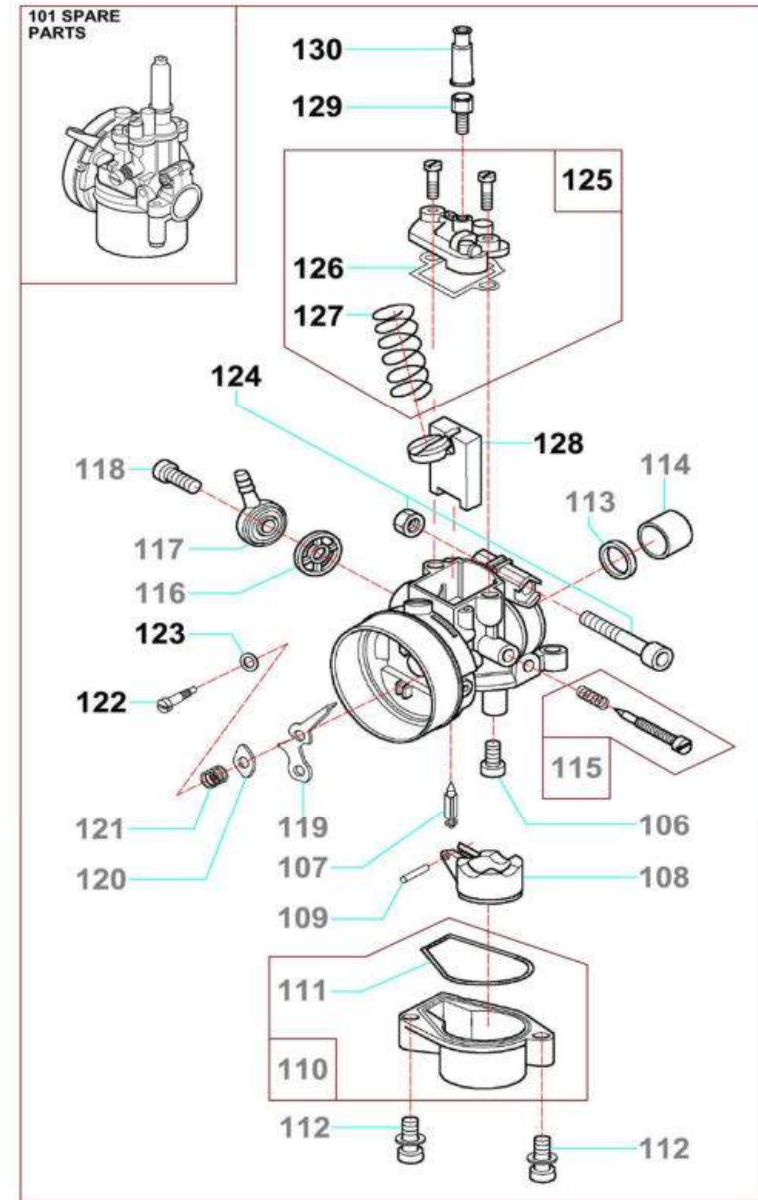

## **C 50 - (disegno 8) - (drawing 8)**

---

<b>Pos.</b>	<b>Cod.</b>	<b>Descrizione</b>	<b>Description</b>	<b>Qt.</b>
122	C050-446-03	Perno valvola aria	Air valve pin	1
123	S060-059	Rondella in ottone D.6,2xD.10x1,5	Brass washer D.6,2xD.10x1,5	1
124	C050-446-04	Kit vite serraggio manicotto	Closing screw kit hose	1
125	C050-442-08	Coperchio valvola completo	Complete throttle gas cap	1
126	C050-442-06	Guarnizione coperchio valvola	Throttle gas cap gasket	1
127	C050-442-07	Molla valvola gas	Gas throttle spring	1
128	C050-442-05	Valvola gas 7	Gas throttle 7	1
129	C050-442-02	Vite tendifilo	Register screw	1
130	C050-442-01	Cappuccio cavo gas	Gas cable cap	1
131	C050-206	Kit guarnizioni	Gaskets kit	1

# C 50 - OPTIONAL 1

## OPTIONAL 1 C 50

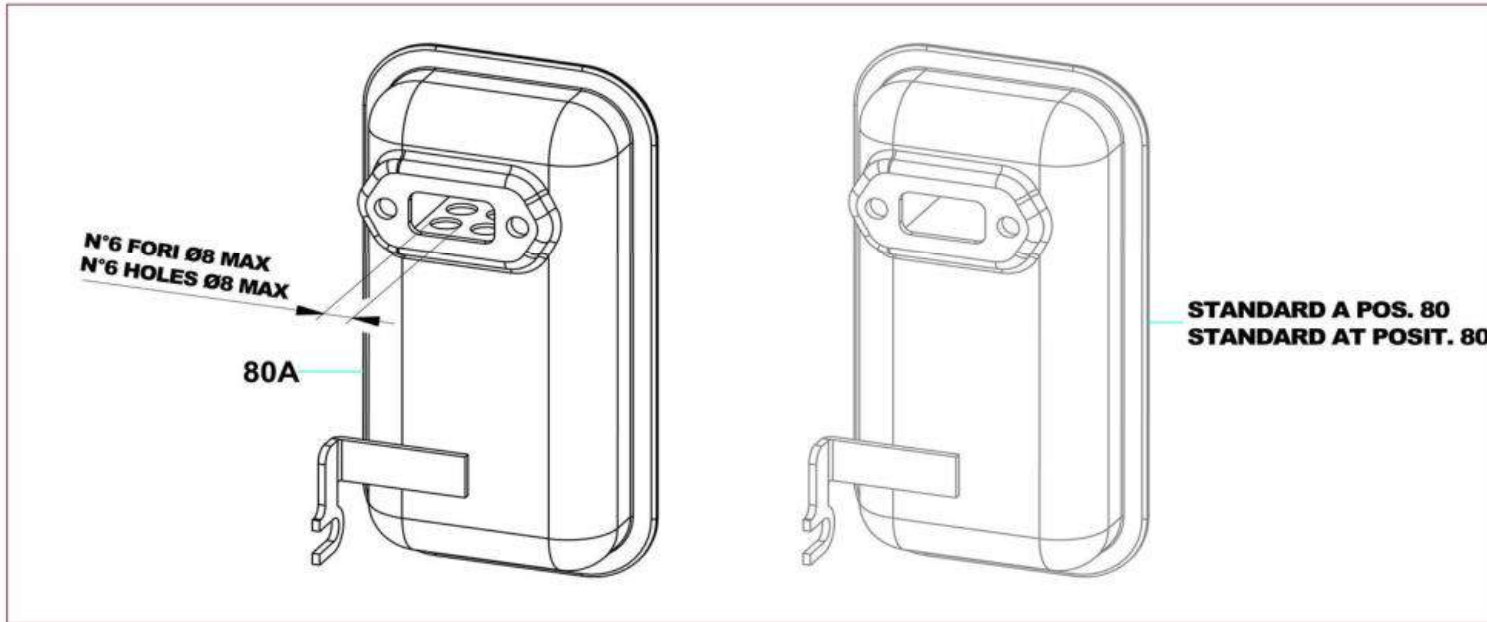
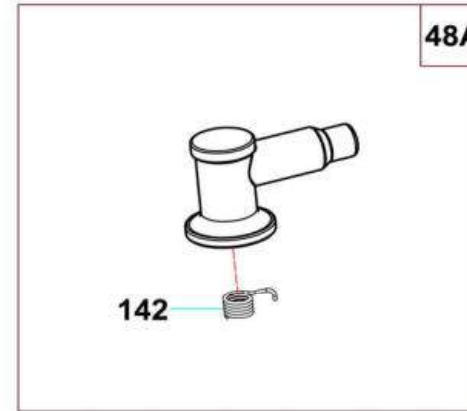

## **C 50 - OPTIONAL 1**

---

<b>Pos.</b>	<b>Cod.</b>	<b>Descrizione</b>	<b>Description</b>	<b>Qt.</b>
36A	S060-093-15	Campana frizione Z11	Z11 clutch drum	1
36B	S060-093-04	Campana frizione Z12	Z12 clutch drum	1
140	S060-094	Rondella trattata D.10,3xD.20x2	Heated washer D.10,3xD.20x2	1
141	NORM-019	Dado Ch.17 M10x1 zincato bianco	Nut key.17 M10x1 white galvanized	1
48A	S060-033	Cappuccio candela silicone rosso con molla	Red silicon spark plug cap with spring	1
142	70001095	Molla per cappuccio candela	Spark plug cap spring	1
80A	C050-034-04	Marmitta a bauletto con fori	Exhaust box with holes	1

# C 50 - OPTIONAL 2

## OPTIONAL 2 C 50

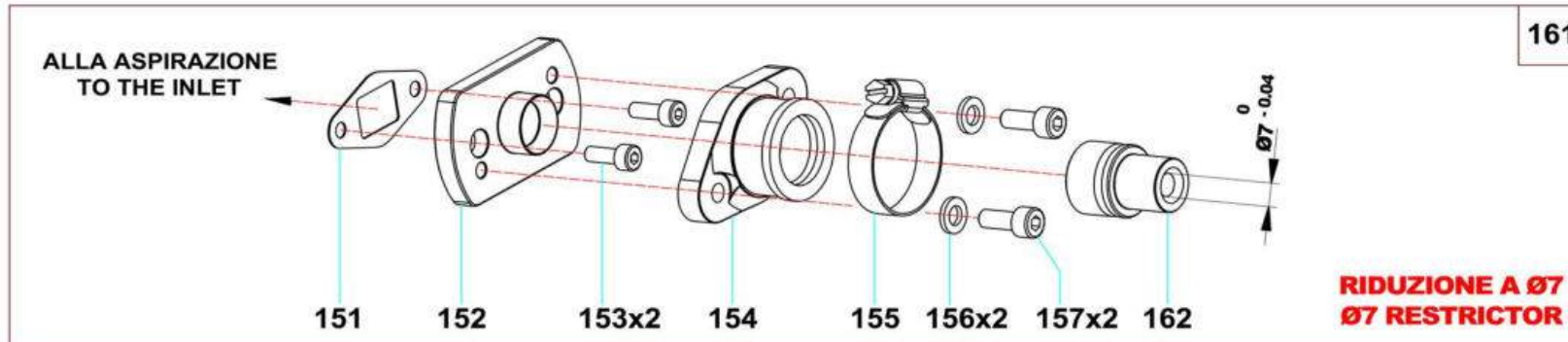
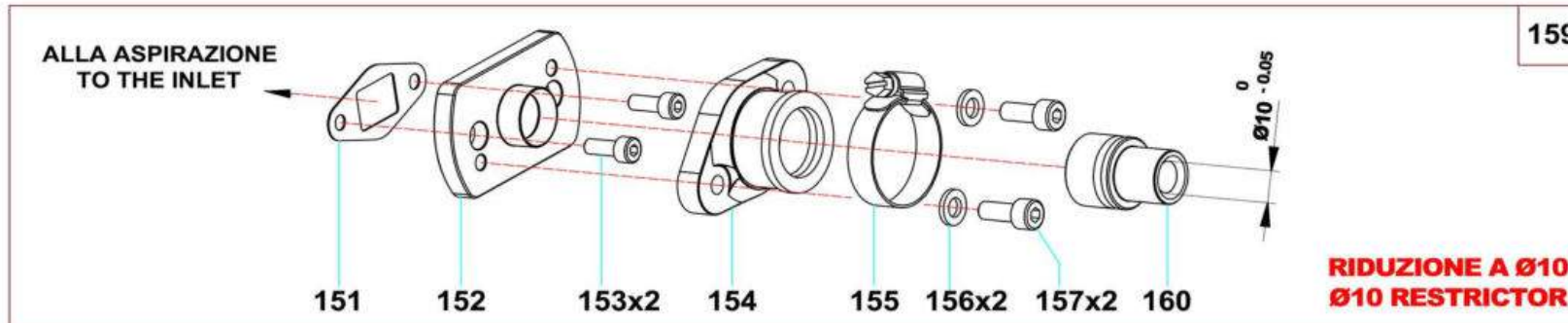
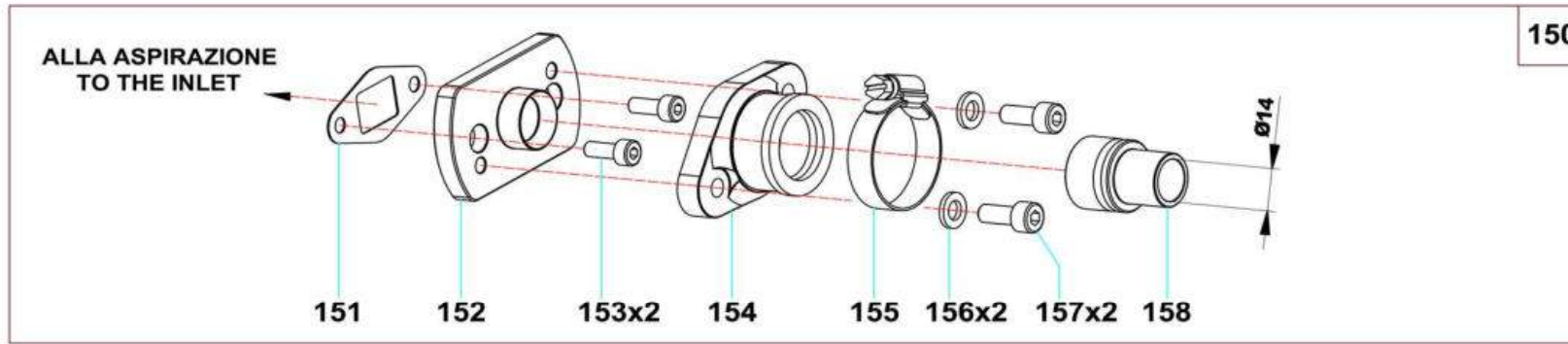



## **C 50 - OPTIONAL 2**

---

<b>Pos.</b>	<b>Cod.</b>	<b>Descrizione</b>	<b>Description</b>	<b>Qt.</b>
150	C050-070-01	Kit collettore aspirazione in gomma	Rubber inlet manifold kit	1
151	C050-069	Guarnizione di aspirazione	Inlet gasket	1
152	C050-089-11	Flangia collettore anod. nera e marchiata	Inlet manifold flange black anodized and marked	1
153	NORM-039-01	Vite TCEI M5x14 zincata bianca	Screw TCEI M5x14 white galvanized	2
154	KWE6-070-02	Collettore in gomma	Rubber inlet manifold	1
155	70001056	Fascetta a vite 20-32 W4	Screw clamp 20-32 W4	1
156	NORM-038	Rondella piana D.6,5xD.12x1,6 zincata bianca	Flat washer D.6,5xD.12x1,6 white galvanized	2
157	NORM-037-02	Vite TCEI M6x16 zincata bianca	Screw TCEI M6x16 white galvanized	2
158	C050-091	Boccola per collettore In gomma	Rubber manifold bush	1
159	C050-070-02	Kit collettore aspir. in gomma riduzione Ø10	Restricted Ø10 rubber inlet manifold kit	1
160	C050-091-06	Boccola Ø10 per collettore in gomma	Ø10 rubber manifold bush	1
161	C050-070-03	Kit collettore aspir. in gomma riduzione Ø7	Restricted Ø7 rubber inlet manifold kit	1
162	C050-091-04	Boccola Ø7 per collettore in gomma	Ø10 rubber manifold bush	1

# C 50 - ACCESSORI - ACCESSORIES

ACCESSORI - ACCESSORIES

C 50

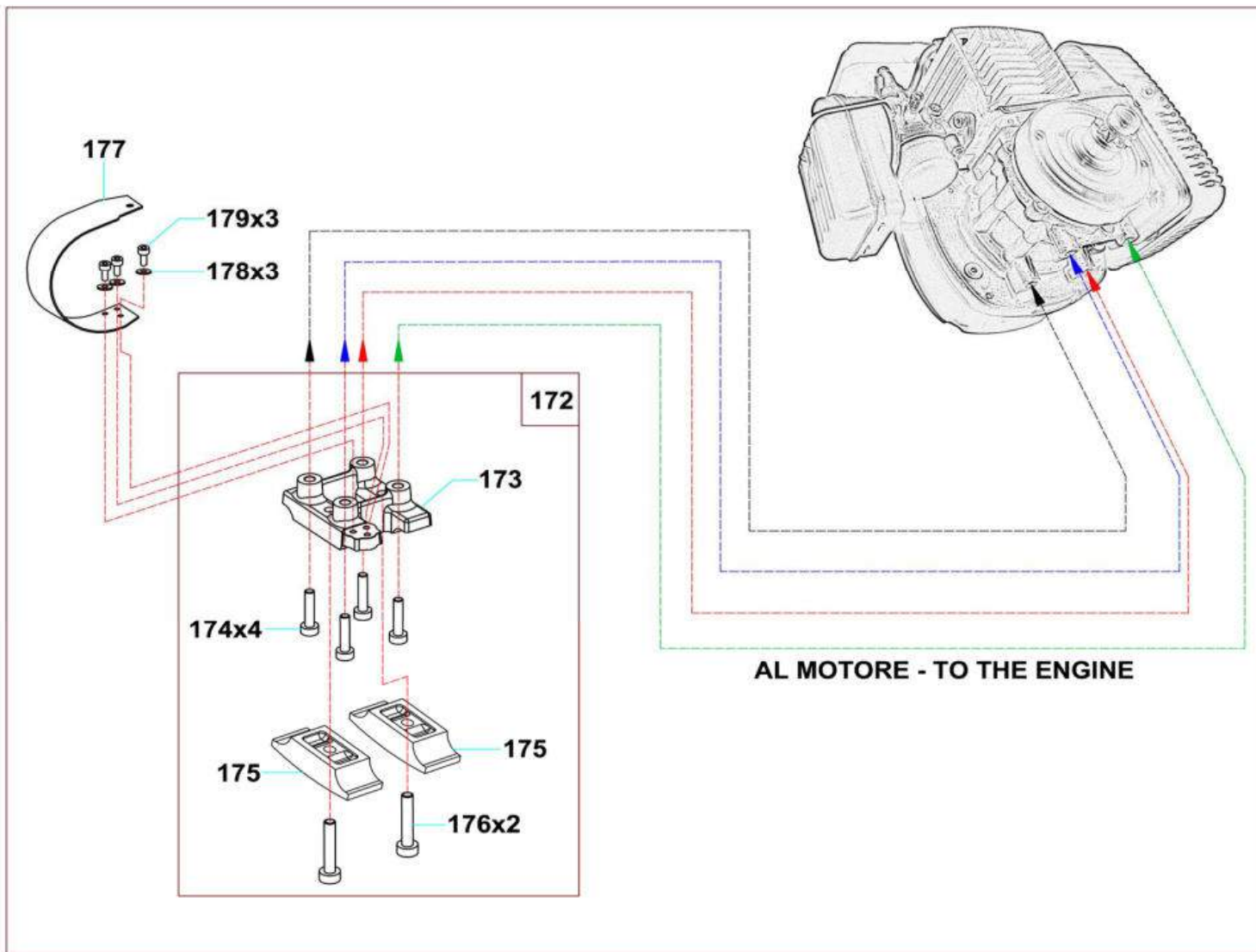

**RIDUZIONE A Ø7  
Ø7 RESTRICTOR**

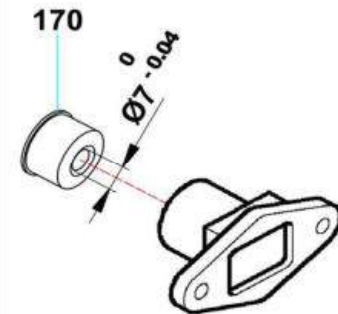

**RIDUZIONE A Ø10  
Ø10 RESTRICTOR**

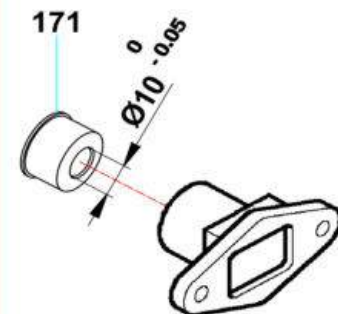

**Comer**

## **C 50 - ACCESSORI - ACCESSORIES**

---

<b>Pos.</b>	<b>Cod.</b>	<b>Descrizione</b>	<b>Description</b>	<b>Qt.</b>
170	C050-071	Boccola riduzione a Ø7	Ø7 restrictor bush	1
171	C050-071-01	Boccola riduzione a Ø10	Ø10 restrictor bush	1
172	C050-200-01	Piastra motore C 50 completa D.26x90	C50 complete engine mount D.26x90	1
173	C050-200	Piastra motore C50 marchiata D.26X90	C50 marked engine mount D.26X90	1
174	NORM-030-03	Vite TCEI M8x40 brunita	Screw TCEI M8x40 burnished	4
175	1000-037-07	Cavallotto in allum. per bloccaggio motore	Engine mount bracket	2
176	1000-038	Vite TCEI M10x40 brunita	Screw TCEI M10x40 burnished	2
177	1000-012-04	Protezione in plastica nera pignone catena	Black plastic chain sprocket protection	1
178	S060-038	Rondella piana D.5xD12x2 zincata bianca	Flat washer D.5xD.12x2 white galvanized	3
179	NORM-306	Vite TCEI M5x10 brunita	Screw TCEI M5x10 burnished	3

ACCESSORI/ACCESSORIES - Non forniti con il motore/Not supplied with the engine

## ATTREZZI - TOOLS

## C 50

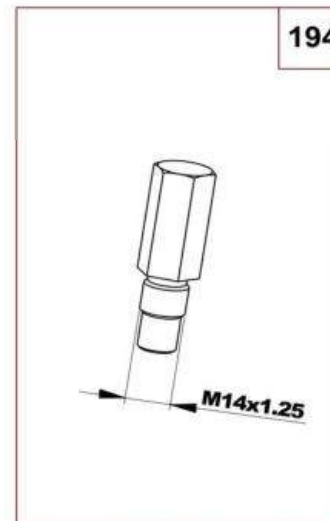
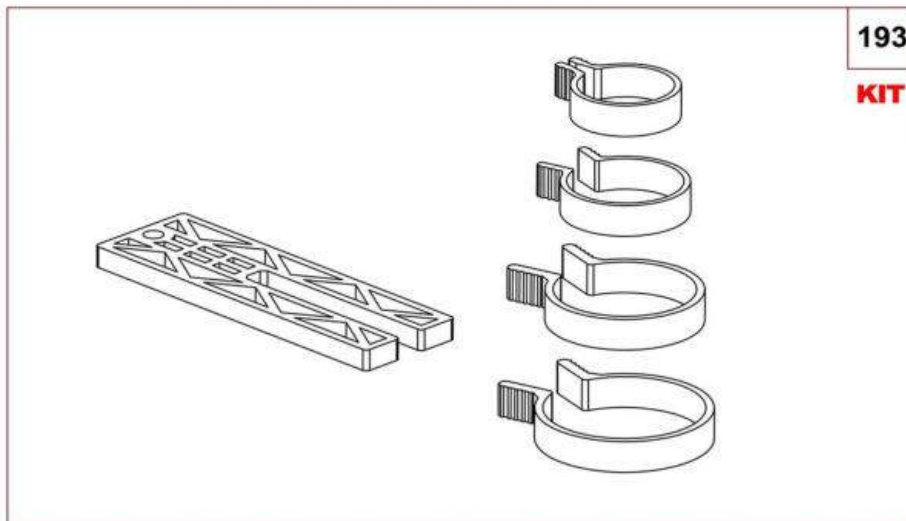
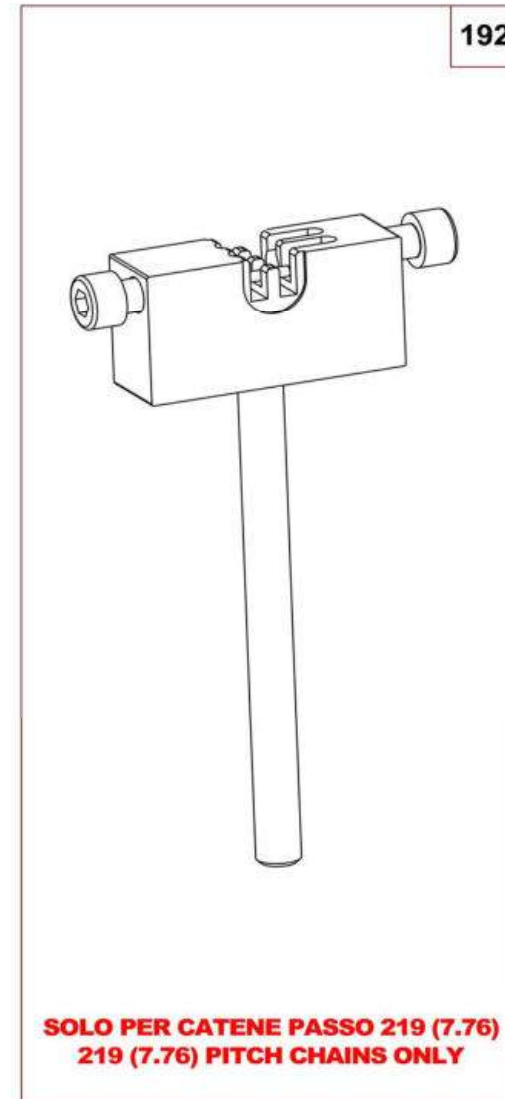
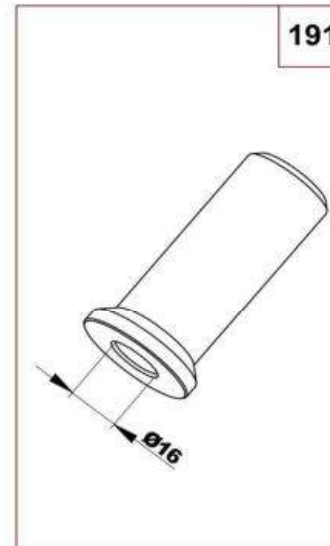
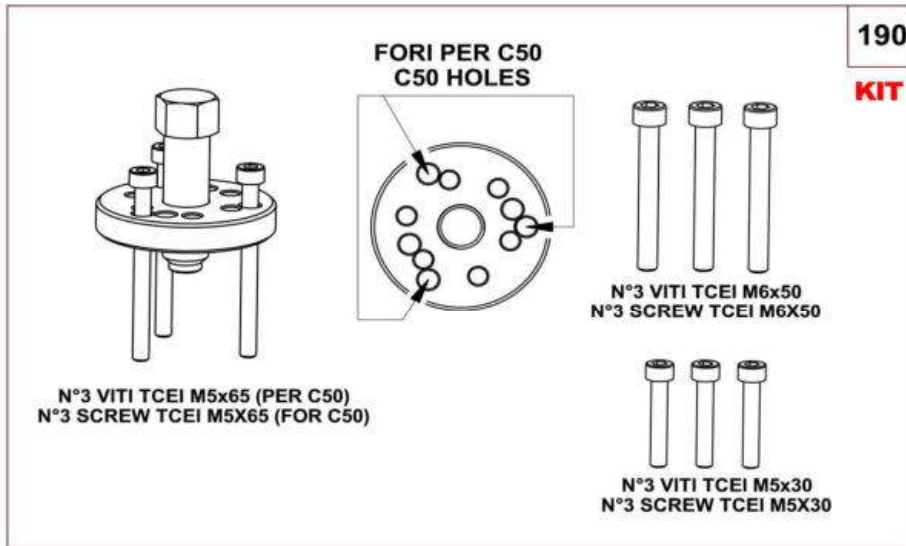

## **C 50 - ATTREZZI - TOOLS**

---

<b>Pos.</b>	<b>Cod.</b>	<b>Descrizione</b>	<b>Description</b>	<b>Qt.</b>
190	KACC-125	Kit estrattore frizione	Clutch puller kit	1
191	KACC-127	Tampone montaggio paraolio foro D.16	Oil seal plug tool hole D.16	1
192	KACC-145	Smagliatore catena Comer	Comer chain tool	1
193	KACC-128	Kit montaggio cilindro	Cylinder assembling kit	1
194	KACC-126	Perno ferma pistone	Stop piston pin	1

ATTREZZI/TOOLS - Non forniti con il motore/Not supplied with the engine



**C50**

**INFORMAZIONI GENERALI - C50**

**GENERAL INFO**

---

<b>COD.</b>	<b>DESCRIZIONE</b>	<b>DESCRIPTION</b>	<b>BOX DIMEN. WxDxH (cm)</b>	<b>PESO - WEIGHT (Kg.)</b>
C050-503	MOTORE C50	C50 ENGINE	30x30x25	6

*Attenzione ! : Il motore non è comprensivo di piastra motore  
Attention ! : The engine mount is not included in the engine.*

---